

**GENERAL ELECTRIC**

**GENERAL ELECTRIC COMPANY  
CORPORATE RESEARCH AND DEVELOPMENT**  

---

Schenectady, N.Y.

AD 724797

**RESEARCH AND DEVELOPMENT PROTOTYPE FOR MACHINE  
AUGMENTATION OF HUMAN STRENGTH AND ENDURANCE  
HARDIMAN I PROJECT**

Prepared by

Specialty Materials Handling Products Operation  
General Electric Company  
Schenectady, New York 12305

1 May 1971

Supported Jointly by

Engineering Psychology Programs Office  
Office of Naval Research  
Washington, D. C. 20360

Naval Air Systems Comma.  
Washington, D. C. 20360

Army Mobility Equipment Research and Development Center  
Fort Belvoir, Virginia 22060  
United States Army Project No. IM62410105072

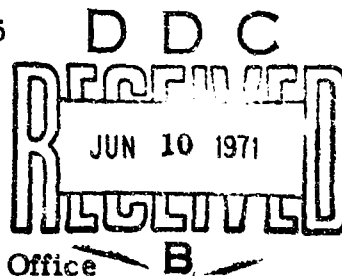

Approved for public release; distribution unlimited.

ONR Contract Number N00014-63-C0051

Work Unit Number NR 196-049

Reproduced by  
NATIONAL TECHNICAL  
INFORMATION SERVICE  
Springfield, Va 22151

S-71-1056

56

Unclassified

Security Classification

DOCUMENT CONTROL DATA - R & D	
<i>(Security classification of title, body of abstract and indexing annotation must be entered when the overall report is classified)</i>	
1. ORIGINATING ACTIVITY (Corporate author) Specialty Materials Handling Products Operation General Electric Company Schenectady, New York 12305	2a. REPORT SECURITY CLASSIFICATION UNCLASSIFIED 2b. GROUP
3. REPORT TITLE Research & Development Prototype for Machine Augmentation of Human Strength and Endurance	
4. DESCRIPTIVE NOTES (Type of report and inclusive dates) Summary of Program progress through 30 April 1971	
5. AUTHOR(S) (First name, middle initial, last name) Makinson, B. John	
6. REPORT DATE 1 May 1971	7a. TOTAL NO. OF PAGES 25 7b. NO. OF REFS
8a. CONTRACT OR GRANT NO. Contract N00014-66-C0051 b. PROJECT NO. IM 62410105072 c. Work Unit No. NR 196-049 d.	9a. ORIGINATOR'S REPORT NUMBER(S) S-71-1056 9b. OTHER REPORT NO(S) (Any other numbers that may be assigned this report)
10. DISTRIBUTION STATEMENT Approved for public release; distribution unlimited.	
11. SUPPLEMENTARY NOTES	12. SPONSORING MILITARY ACTIVITY Engineering Psychology Programs, ONR Naval Air Systems Command; and U. S. Army Mobility Equipment Research and Development Center
13. ABSTRACT Summary of progress and achievements on the Hardiman I Prototype Project. This report covers the period from 1970 January through 1971 April.  The major accomplishment during this period has been the completion of the fabrication and mechanical assembly of the Hardiman I Prototype.  <p style="text-align: center;">Details of illustrations in this document may be better studied on microfiche</p>	

DD FORM 1 NOV 63 1473

Unclassified

Unclassified

Security Classification

14. KEY WORDS	LINK A		LINK B		LINK C	
	ROLE	WT	ROLE	WT	ROLE	WT
Hardiman						
Exoskeleton						
Manipulator						
Bilateral Servos						
Joints-in-series						
Man-augmentation Systems						
Human Factors						

Unclassified

Security Classification

RESEARCH AND DEVELOPMENT PROTOTYPE FOR MACHINE  
AUGMENTATION OF HUMAN STRENGTH AND ENDURANCE

HARDIMAN I PROJECT

Supported Jointly by

Engineering Psychology Programs Office  
Office of Naval Research  
Washington, D. C. 20360

Naval Air Systems Command  
Washington, D. C. 20360

Army Mobility Equipment Research and Development Center  
Fort Belvoir, Virginia 22060  
United States Army Project No. IM62410105072

Work Unit Number NR 196-049

ONR Contract Number N00014-66-C0051

1 May 1971

Prepared by

Specialty Materials Handling Products Operation  
General Electric Company  
Schenectady, New York 12305

Approved for public release; distribution unlimited.

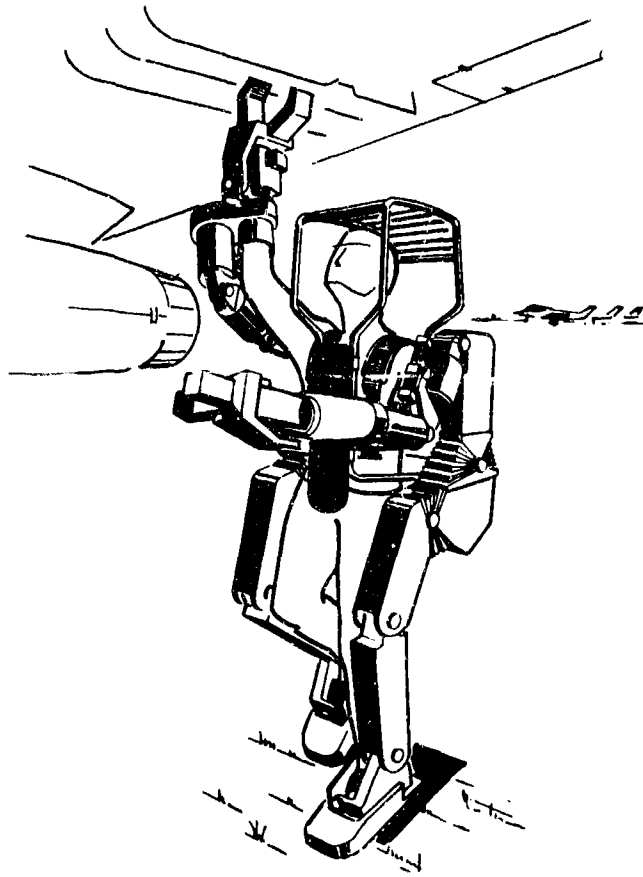

### THE POWERED EXOSKELETON PROJECT

The Powered Exoskeleton concept is that of a material-handling machine under intimate control of the operator.

"Worn as an outer mechanical garment, the exoskeletal structure will be powered to dramatically amplify the wearer's strength and endurance by a factor of approximately 25 to one, i. e., when the exoskeleton wearer lifts 25 pounds, he will 'feel' as if he is lifting only one pound. The device will provide him with a set of 'mechanical muscles' that enables him to lift and handle loads in excess of 1000 pounds. The human operator will 'feel' the objects and forces he is working with almost as if he were in direct body and muscle contact. This feature, called force feedback, will provide the operator with sensitive control of the structure and will act as a safeguard against the application of excessive force.

"The exoskeleton, called 'Hardiman,' mimics the movements of its wearer, presenting a literal union of man and machine. Thus, the human's flexibility, intellect, and versatility are combined with the machine's strength and endurance. "\*

\* Naval Research Reviews, July 1967

## FOREWORD

The implementation of the Hardiman powered exoskeleton concept has now been carried to the point where a prototype unit, consisting of 30 hydraulically powered, servo-controlled joints has been fabricated and mechanically assembled.

One of the arm assemblies has previously been operated and has met basic design objectives under test. Details of this test were covered in the previous General Electric Company technical report S-70-1019.

The Leg and Girdle System has also been completed and has gone through partial testing of its twelve servo-controlled joints.

The remaining activities on this program will consist of limited walking experiments and debugging of the complete prototype system.

TABLE OF CONTENTS

<u>Section</u>		<u>Page</u>
	The Powered Exoskeleton Project .....	ii
	Foreword .....	iii
	List of Illustrations .....	v
I	Introduction .....	1
II	Program Summary .....	3
III	Program Plans .....	17
IV	Looking Ahead .....	19
	Appendix	

## LIST OF ILLUSTRATIONS

<u>Figure</u>		<u>Page</u>
1	Hardiman I	
2	Hardiman I Arm System . . . . .	4
3	Arm System with 750 Pounds . . . . .	5
4	Hardiman Leg and Girdle Assembly . . . . .	6
5	Hardiman Leg and Girdle System - Operator Attachment . . . . .	7
6	Hardiman I Prototype Assembly - 90th Percentile Operator. (Machine Partially Complete, Not Yet Operable.) . . . . .	8
7	Hardiman I Prototype Assembly - 17th Percentile Operator. (Machine Partially Complete, Not Yet Operable.) . . . . .	10
8	Hardiman I Prototype Assembly. Backpack Removed to Show Master Linkage . . . . .	11
9	Hardiman I - Leg Master Assembly . . . . .	13
10	Hardiman I - Right Arm Showing Master Attachment . . . . .	14
11	Boom Unloading Container . . . . .	20
12	Servo-controlled Cargo Boom Adapted for Rapid Loading of Missile Clips Weighing 7500 Pounds . . . . .	21
13	Two-arm Loader Concept for Ordnance Loading A Carrier-based Aircraft . . . . .	22
14	Angular Excursion of Joints . . . . .	24



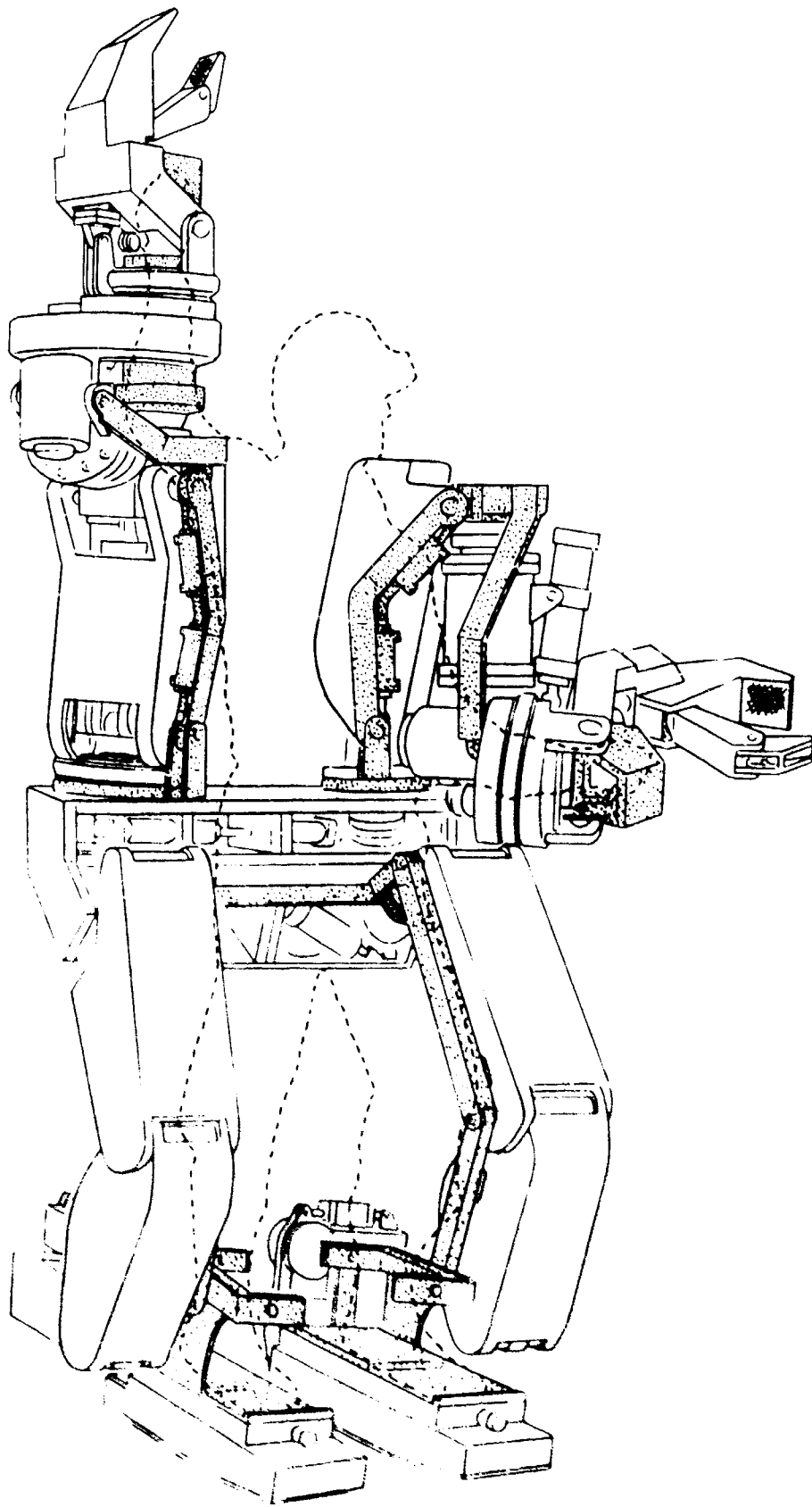

Figure 1. Hardiman I

## Section 1

### INTRODUCTION

The research contract for the development of Hardiman I was initiated as a joint Army-Navy program in November 1965.

The goal of this program is to develop and demonstrate the potential of a powered exoskeleton. This is a powered, jointed, load bearing structure designed to be worn by man and augment his strength and endurance. Typical applications for the Hardiman I will include loading and unloading cargo from vehicle to ground and vice versa, stacking and moving cargo from place to place, and similar associated tasks. The Hardiman I will be designed so that the wearer can walk, bend, turn, etc., with minimum restraint.

The exoskeleton design concept is shown pictorially in Figure 1.

The exoskeleton system is a master-slave device. That is, there are two complete "skeletons" -- the exoskeleton proper or slave, which carries the working load, and a master skeleton which is attached to the operator. The master skeleton is the shaded portion in Figure 1. Each joint of the exoskeleton has a duplicate on the master. The master and slave are geometrically superposed so that corresponding joint axes are approximately collinear.

The operator is attached to the master skeleton at appropriate places, and can cause the slave to assume desired postures and hand positions by moving the master. The bilateral servos reflect the working forces of the slave to the operator, reduced by a factor of 25, so that he can sense the operation of the machine as it works.

The operator stands inside this structure, to a large extent surrounded and protected by it. Just below the elbow, the operator's arm, the master, and the slave become concentric. There are several advantages to this: the controls are simplified, human factor correspondence is improved by having the slave hand in axial line with the operator's hand, and the operator's hand is protected by being inside the slave housing.

In the first laboratory prototype, electric and hydraulic power will be supplied through an umbilical connection. Future versions may incorporate a self-contained power supply.

Since the man and machine must be so intimately coordinated in this device, the human factors related to the man-machine interface and control system play a crucial role in its design. Early in the program, it was found that much of the human factors data that might have been applied were not

available in forms readily applicable to this concept. The required information was developed from existing sources and augmented by laboratory studies using mockups simulating possible configurations of joint designs. It is apparent that the operation and test of the Hardiman I prototype will in itself generate and greatly clarify human factors data in the area of walking anthropomorphic machines and other man-augmentation devices.

Section II  
PROGRAM SUMMARY

The last technical report\* issued on this contract described the test of a complete arm assembly consisting of eight powered joints. This test marked the first time that a major sub-assembly containing more than three bilateral joints in series had been operated through its full dynamic range. The arm system achieved stable operation of all joints up to its full rated load of 750 lb.

Prior to this test, operation of single joints and a unilateral three-jointed leg sub-assembly had confirmed the basic servo designs. The arm test, however, provided the first opportunity to observe and evaluate basic task performance characteristics and to make an initial assessment of the man-machine interface.

Figure 2 is an overall view of the arm as tested. Figure 3 shows the full load test. With its two arms, the completed prototype will be able to lift the design load of 1500 lb.

With successful operation of the arm system established, the next major milestone was to demonstrate walking capability. During 1970, the principal activity on the program was the completion of the Leg and Girdle assembly shown in Figures 4 and 5.

In December of 1970, the Leg and Girdle system was completed and all joints had been operated individually. Further testing of the Leg and Girdle system was then temporarily suspended, and emphasis was placed on completing the second arm, the last sub-assembly required for completion.

Figure 6 shows the Hardiman prototype as it appeared on April 12, 1971. At that time, both arms were mechanically assembled to the Leg and Girdle system for the first time.

This trial assembly was made to check for possible interference between moving parts and the Kinematics of the overall machine.

The left arm in this photograph is the same one shown in Figures 2 and 3 and referred to earlier in the text. It is a fully functioning system with all hydraulic and electrical control components in place.

---

\*Hardiman Arm Test, Hardiman I Prototype, Project, General Electric Report S-70-1019, Dec. 31, 1969

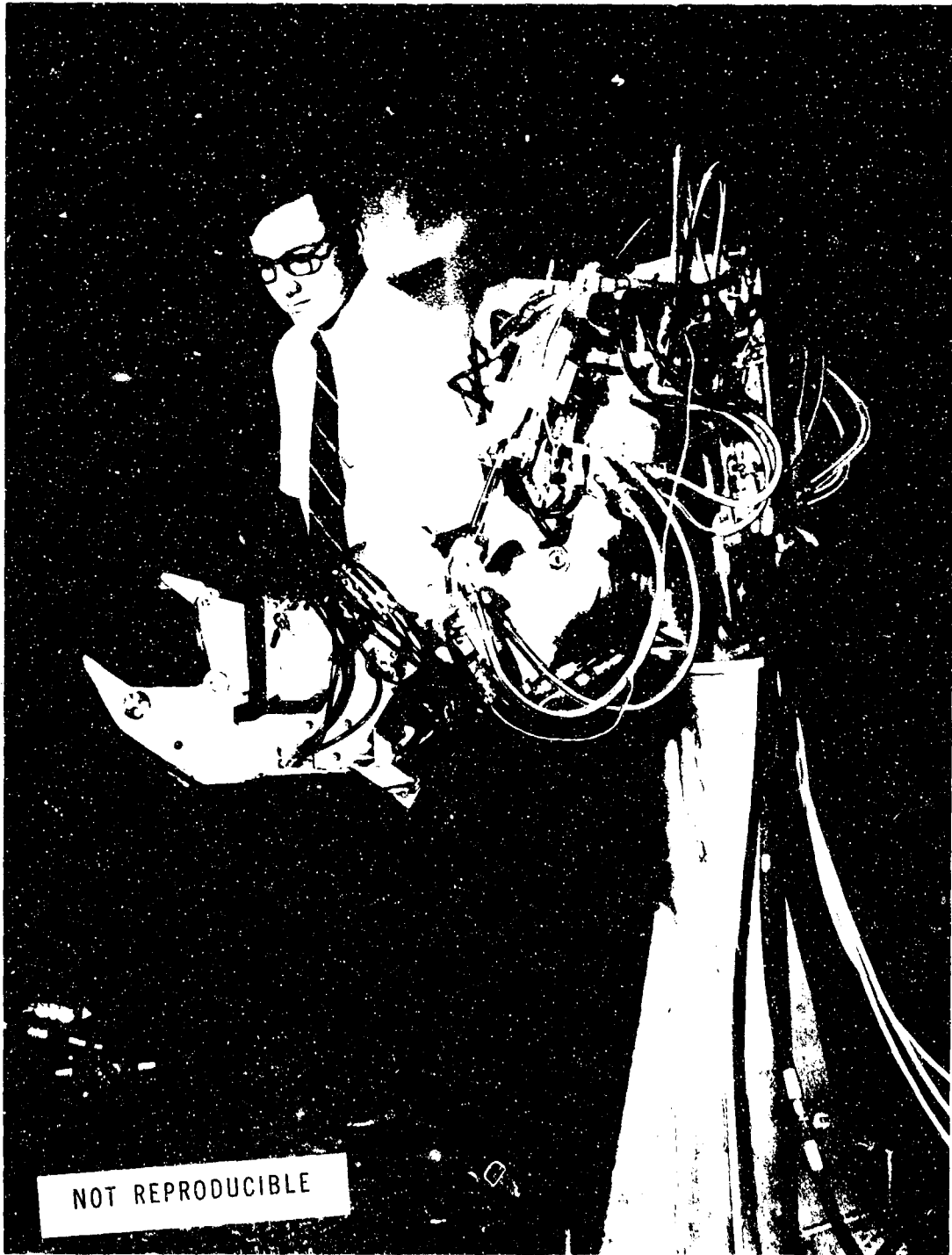

Figure 2. Hardiman I Arm System

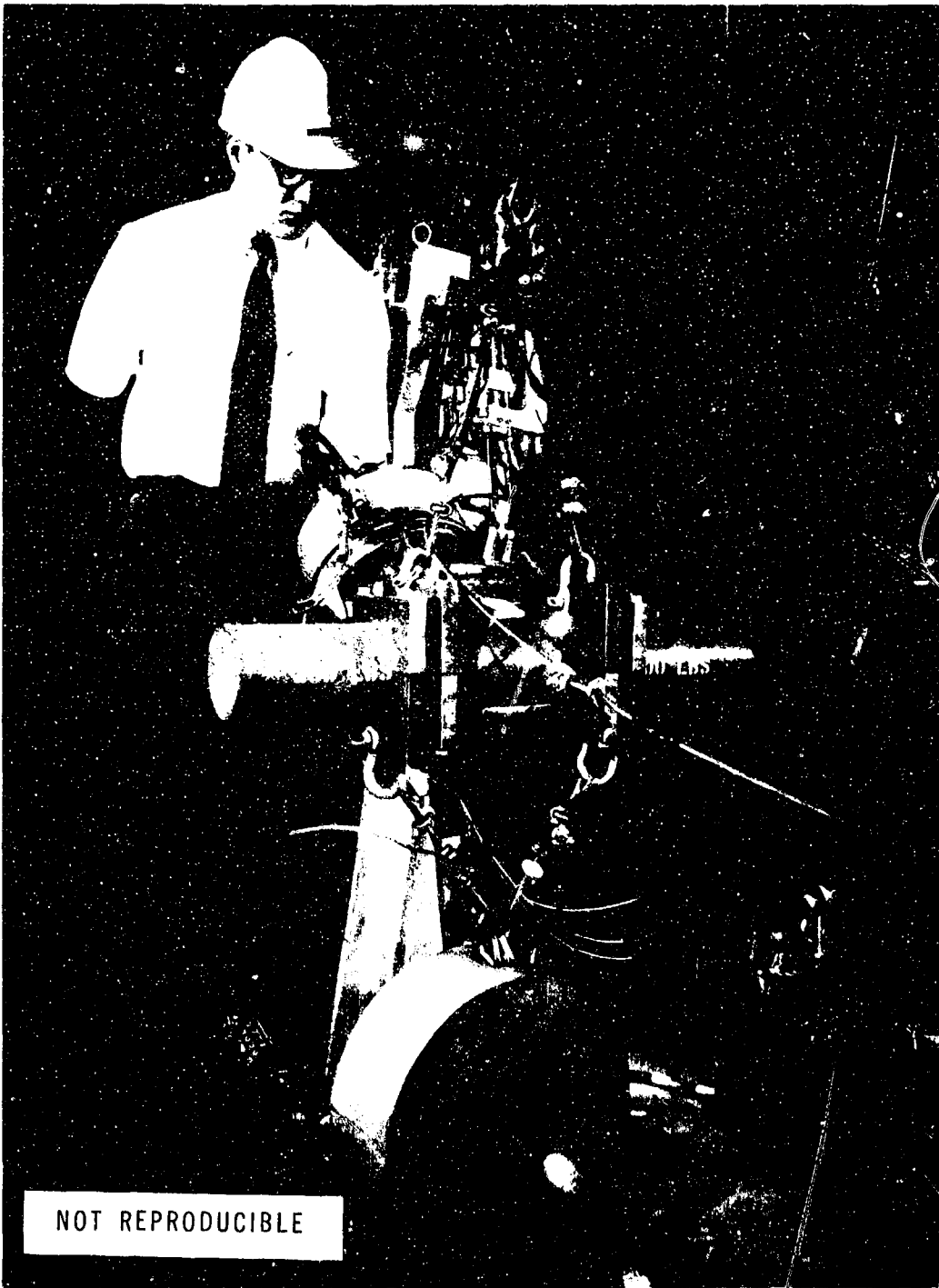

Figure 3. Arm System with 750 Pounds

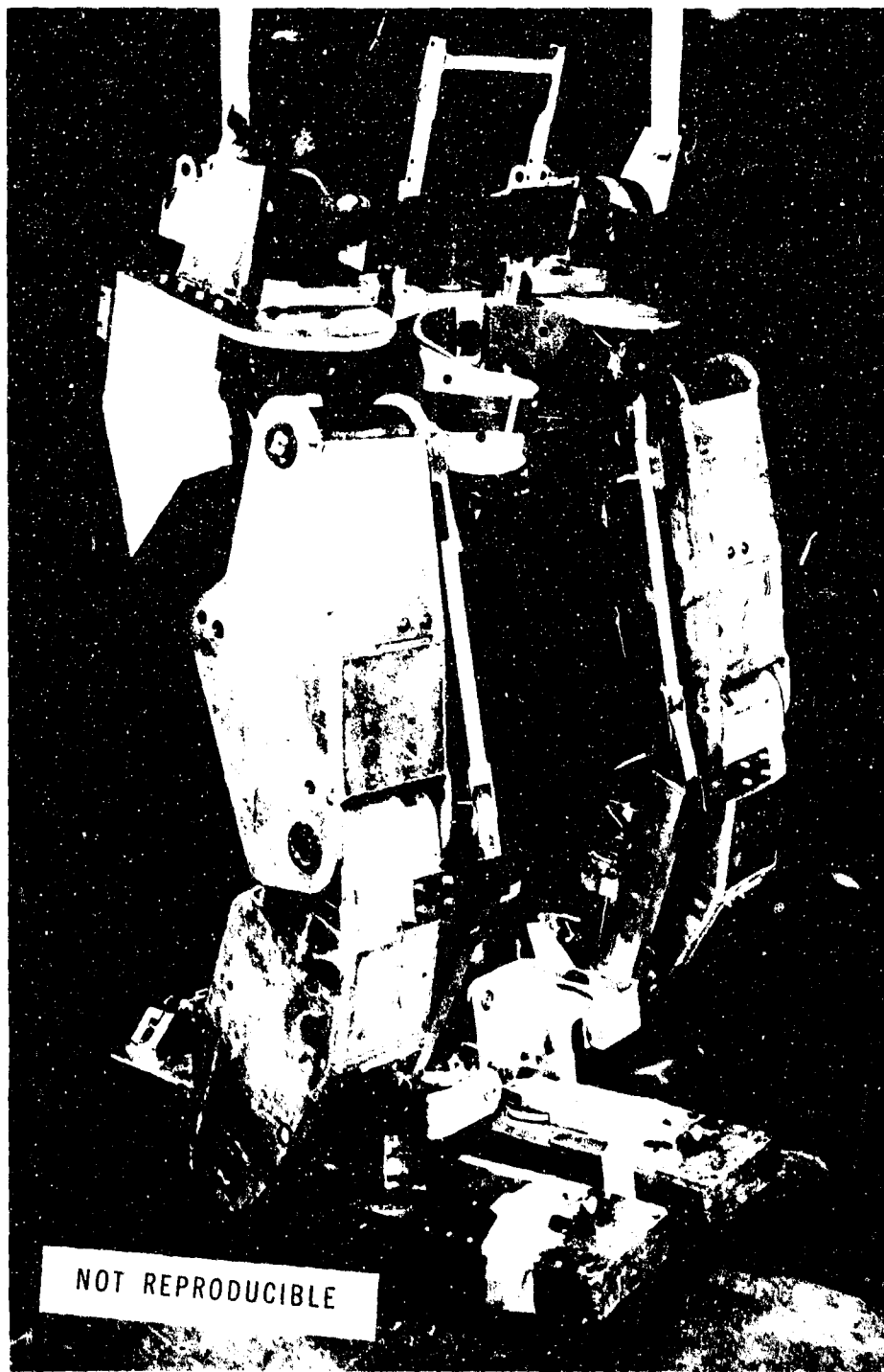

Figure 4. Hardiman Leg and Girdle Assembly

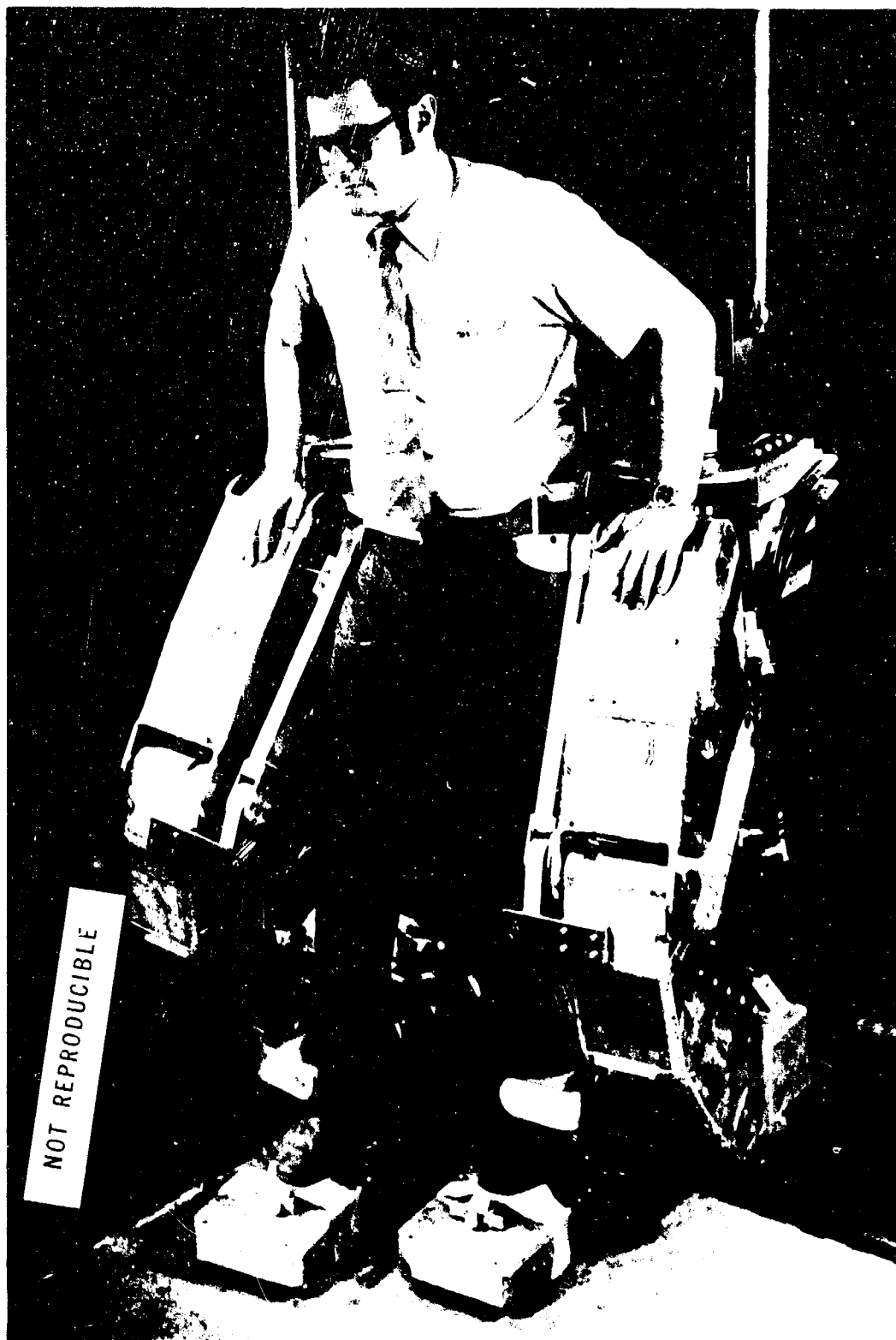

Figure 5. Hardiman Leg and Girdle System - Operator Attachment





Figure 6. Hardiman I Prototype Assembly - 90th Percentile Operator.  
(Machine Partially Complete, Not Yet Operable.)

At the time the photograph was taken, the right arm mechanical assembly had just been completed. All master and slave actuators had been installed, but hydraulic hoses and servo valves had yet to be mounted. Also, electric wiring to the control transducers and servo valves was not completed.

The operator attachment points can be clearly seen in this illustration. The operator's feet are attached to the foot masters by a mechanism resembling ski bindings.

The next attachment point is at the operator's waist by means of the pack harness shown. There are no attachments at the individual leg joints in between. This allows the operator maximum freedom of movement while providing complete control of all leg and foot joints.

The hip Ab-Ad, hip flex, and knee flex form a constrained linkage which follows the motion of the operator's ankle joint. That is, there is only one combination of joint angles in this linkage corresponding to any spatial position of the ankle pivot.

The ankle joint has three intersecting axes providing ankle flex, ankle inversion, and foot rotate motions.

Thus, complete positional control of the legs is achieved through spatial position and angular orientation (in three axes) of the ankle joint.

This minimization of attachment points makes the leg system easily adaptable to operators of different height. This can be seen by comparing the leg joint angles in Figure 6 showing a 90th percentile operator with Figure 7 showing a 17th percentile operator.

In the arm system, the operator attachments are again confined to the terminal points. The operator's hands are inserted into the tubular forearm master to reach the handgrips which control the thumb and thumb tip motions. These handgrips are mounted inside the boxlike hand master seen in both figures just below the right-hand joints. The end plate of the master hand has been left off to show the fingers of the operator's right hand in position. This shows most clearly in Figure 7.

In Figure 6, the lower palm of the operator's left hand can be seen through the opening between the hand master and the forearm rotate joint.

The hand grip and sleeve arrangement allows the operator to introduce torques which control the angular orientation of the hands. Motions of his arms, shoulders, and torso permit him to spatially position the center of these angular motions.

Figure 8 shows the prototype without the operator. The back pack

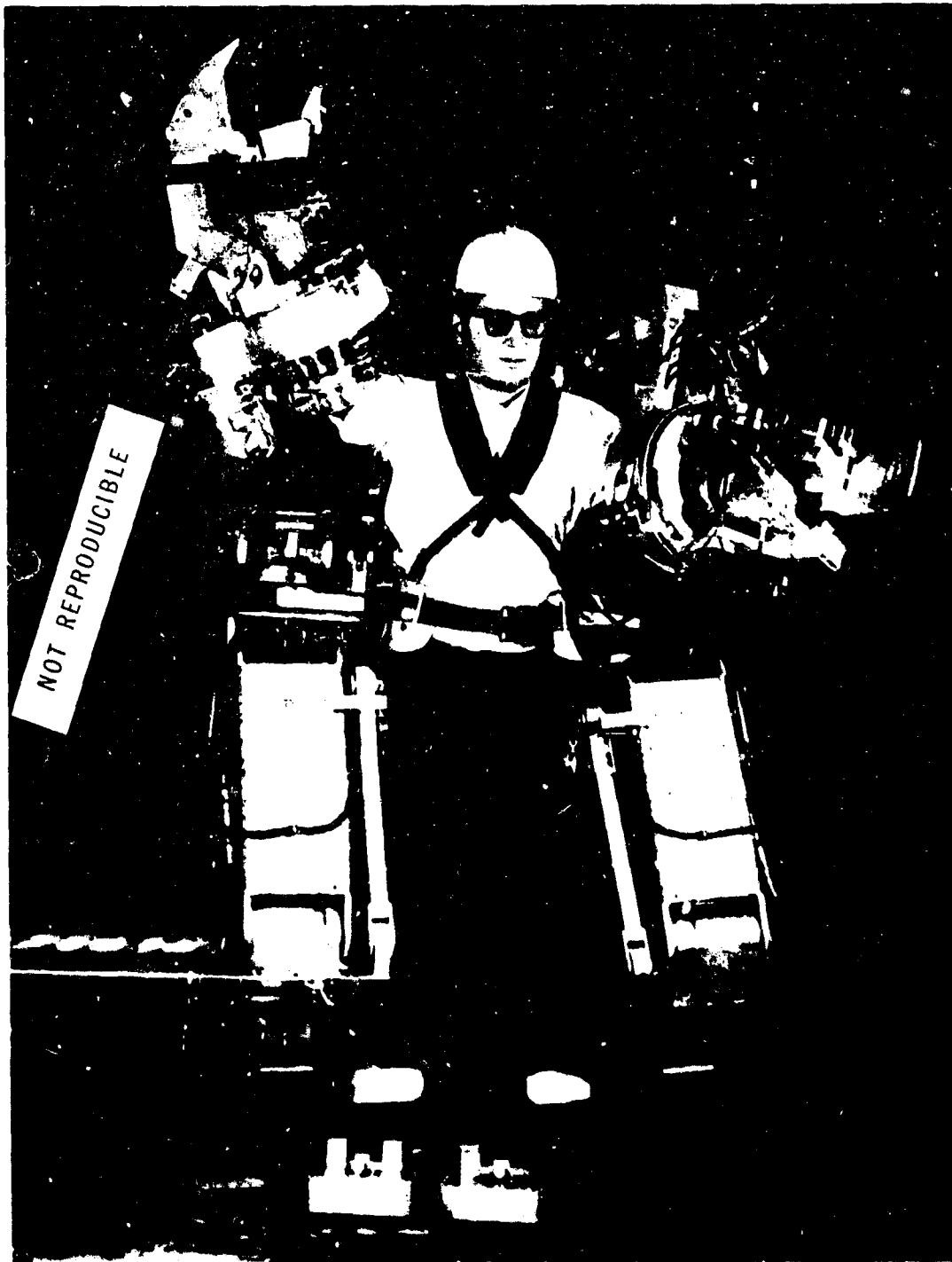

Figure 7. Hardiman I Prototype Assembly - 17th Percentile Operator.  
(Machine Partially Complete, Not Yet Operable.)

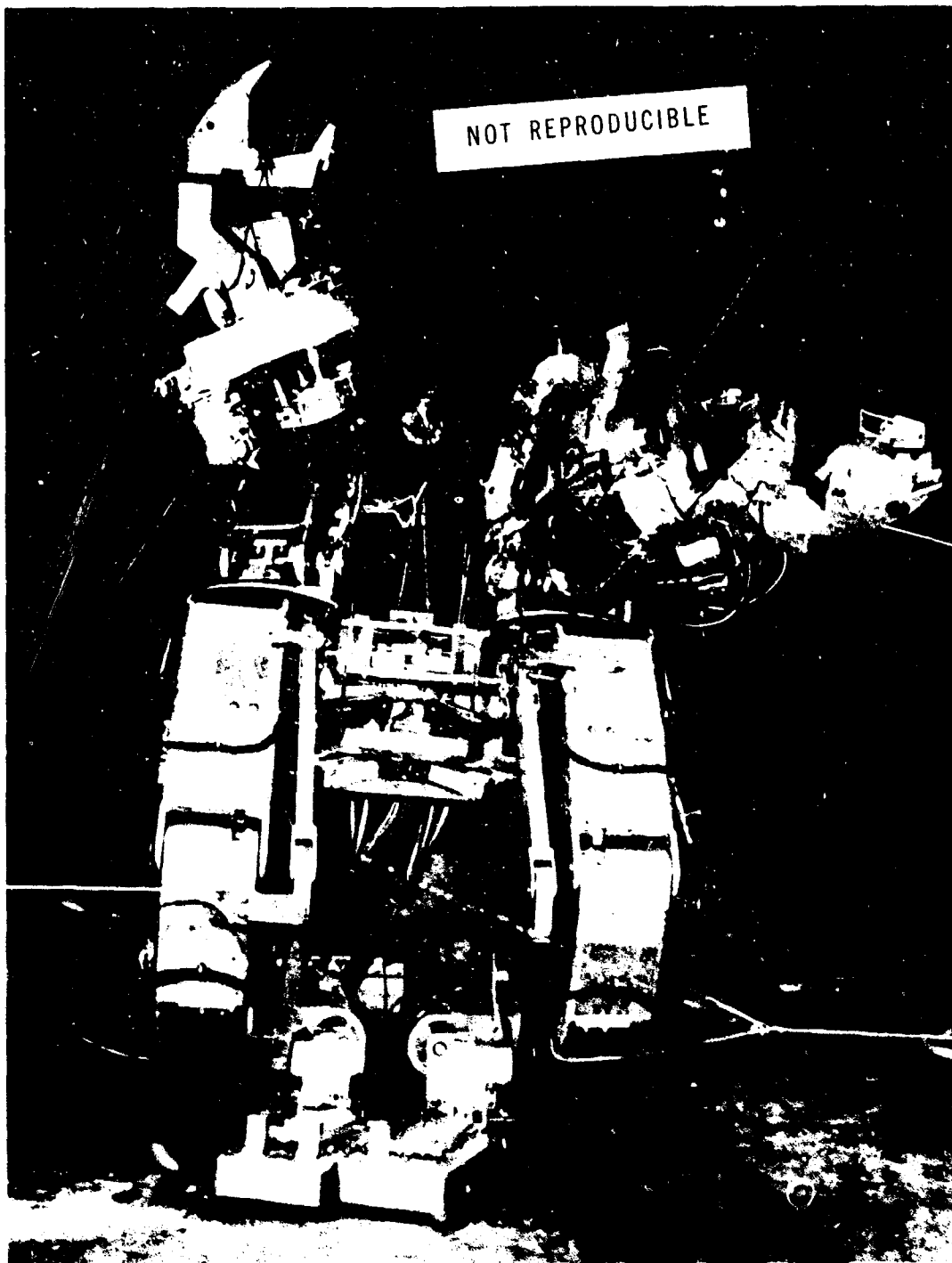

Figure 8. Hardiman I Prototype Assembly. Backpack Removed to Show Master Linkage.

harness (which can be seen in Figure 4) has been removed to permit a complete view of the master linkages.

The master linkage can be most easily traced by comparing the Figure 8 photograph with the Figure 1 sketch, in which the master is shaded to contrast it with the slave or load-bearing structure.

The leg master can be traced from one foot, up its corresponding leg to the girdle, across the girdle to the opposite side and down the second leg to the corresponding foot. This is even more clearly shown in Figure 9.

The arm system has two separate master assemblies, one for each arm. Each of these terminates in an attachment at the back flex joint where both master and slave are grounded to the girdle. Figure 10, showing the newly completed right arm, clearly illustrates the arm master grounding point.

By contrast, the leg master is not grounded to the slave structure at any point. It is essentially a "floating" assembly with no connection to the slave other than the signal generating linkages.

This emphasizes the fact that there are basic differences in the control philosophies related to the arm and leg systems.

Each arm can be considered a fully functioning entity in itself. In effect, each arm is a manipulator mounted on a moving platform. These can operate singly or jointly as a given task requires.

In the leg system, the function of the two legs is more intimately related and the complete leg system must be considered as a unit for control purposes.

A significant feature in the leg control system is the change in operating mode between foot-on-ground and foot-in-air conditions. When the feet are on the ground, control of the leg system is initiated by motions of the operator's hips relative to the stationary feet. When a foot is raised from the ground, its position is then controlled by motions which originate at the master foot. When the foot is again grounded, control must be transferred to the hip.

The Hardiman servos employ a "tickler" input system which has been described in previous reports. This system directly measures displacement between master and slave joints, rather than calculating it from combined angular displacements. This feature was essential in minimizing relative master and slave displacement in this multi-jointed system.

However, the tickler system is nonsymmetrical, in that the gain at the free moving end of the system is greater than that at the grounded end. Since either end (foot) can be grounded or free, it was necessary to have two

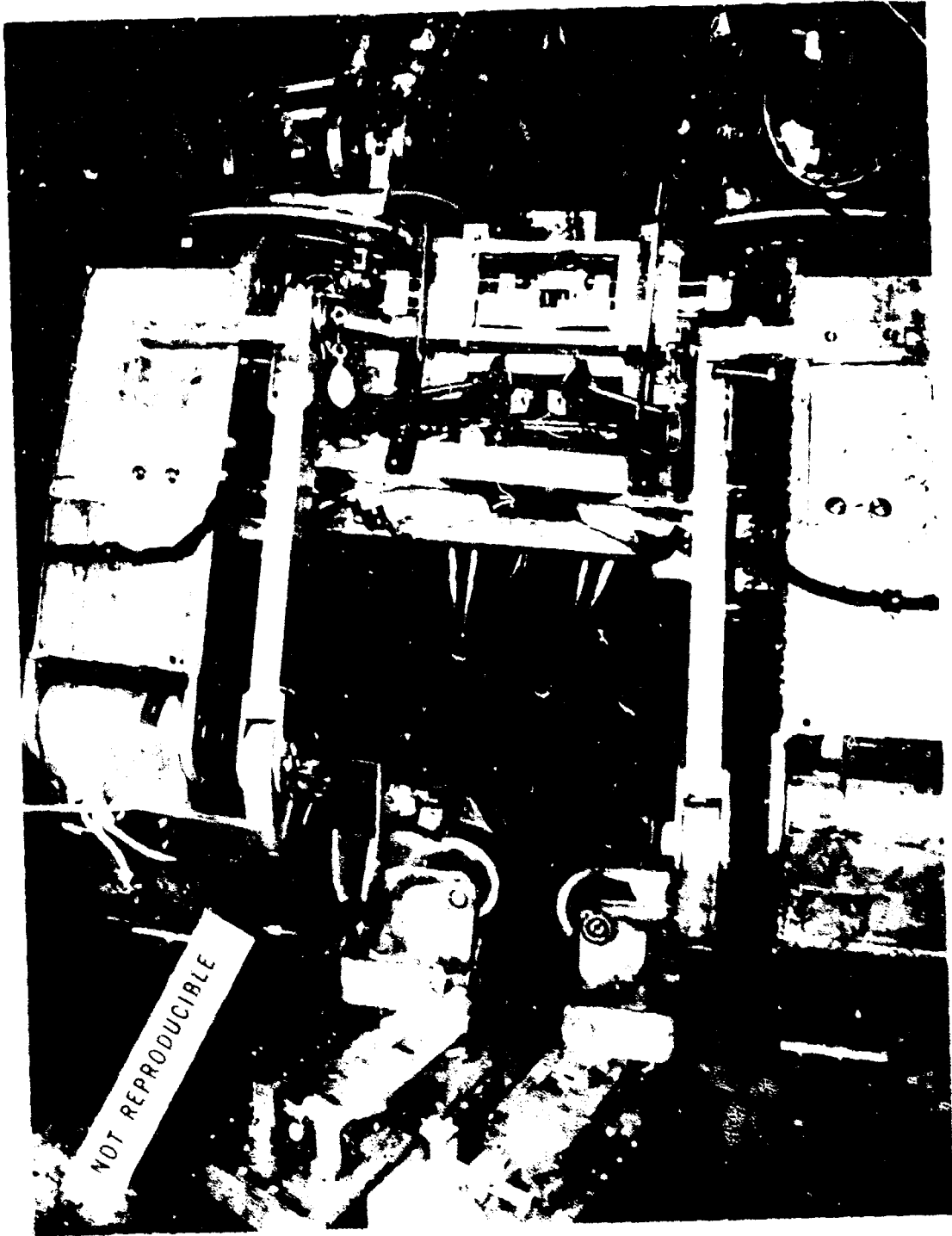

Figure 9. Hiram and I - Leg Master Assembly

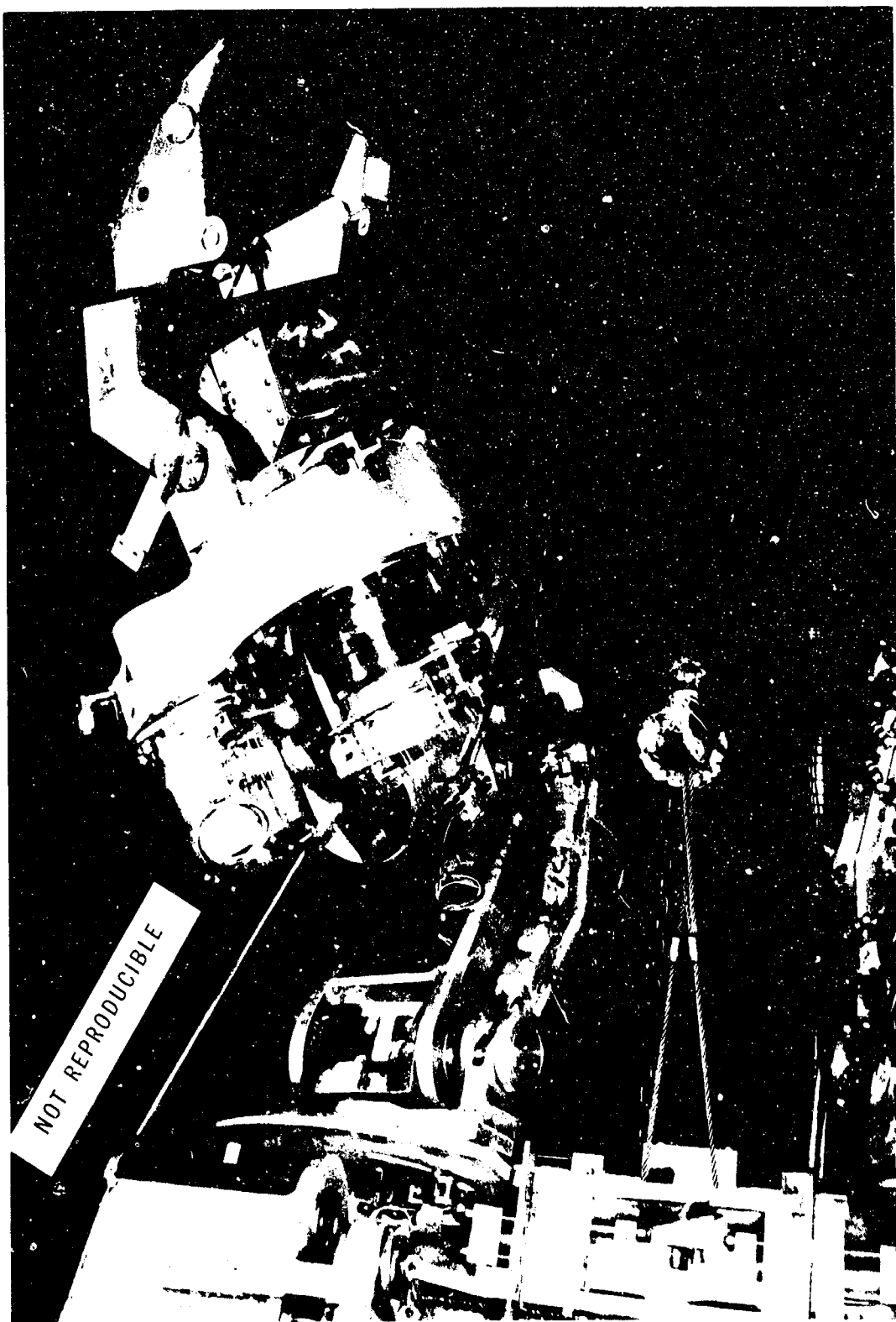

Figure 10. Hardiman I - Right Arm Showing Master Attachment

"tickler" or sensing systems in each leg joint and to switch control depending on which foot is grounded.

The transfer of control is accomplished by switches in the feet which respond to contact forces between master and slave feet. The control electronics include means of smoothing the switching transients due to differences in error signals at the moment of switching.

To further illustrate the control mode, when the left foot is raised from the ground, control of the left leg originates at the left foot, while control of the right leg originates at the right hip. With the right foot raised, the opposite condition applies.

It may help to think of this not as a leg system, but as a system of twelve linked joints, either end of which can be grounded. There is also the special case in which both ends are grounded with control transferred to the mid-point.

The details of the development of this control system and the alternates explored are contained in earlier reports on this program which are listed in the Appendix.

Although the arm system masters are separate from the leg system master, forces felt in the arms generate forces in the operator's legs which result in a set of natural foot reaction forces. For this reason, the leg servos need not directly reflect forces back to the operator's legs.

In the end, it is the operator who forms the integrating link between the arm and leg controls with their special and differing functions.



Section III  
PROGRAM PLANS

With mechanical completion of the prototype unit, the Hardiman I program as defined by the existing contract is rapidly approaching its completion.

After completing the mechanical assembly in April, both arms were removed to permit initial walking experiments with the Leg and Girdle system alone.

Preparations for this test during April relate to safety measures to minimize the chance of operator injury during the startup de-bugging and testing period. Temporary modifications to limit joint velocity and motions will be made by adding adjustable valve flow limits and mechanical stops. These may be removed as predictable performance is attained.

Walking experiments are now scheduled to begin in late May or early June. Controllability of the leg system, ability to balance, and the quality of locomotion achieved will be the principal evaluation criteria. The extent of this experiment will be limited by the amount of funding available. Therefore, it is difficult to predict what level of success will be achieved. As in all new developments, there is always the haunting fear that the necessary de-bugging may be more extensive than anticipated.

Sufficient funding will be reserved to assure that the complete prototype will be assembled, wired, and plumbed. Any remaining funds will be applied to demonstrate basic functions.

During the walking experiment period, the hydraulic and electrical assembly of the right arm will be completed and made ready for the final assembly.

We anticipate completion of all activities under the present contract by July 31, 1971.

## Section IV

### LOOKING AHEAD

The successful implementation of the Hardiman concept for evaluation of its feasibility has produced many significant advances in the technologies related to man-augmentation systems.

Besides their direct application to Hardiman, these technological advances have provided the basis for other investigations into the field of man-augmentation.

Under Contract DAAK 02-70-C-0420, issued by the Army Mobility Equipment Research and Development Center, General Electric Company performed a design study to determine the feasibility of applying the servo technology developed in Hardiman to the handling of cargo and missiles with loads ranging up to 7500 lb at 15 feet (Figures 11 and 12).

A second contract is now being negotiated with MERDC for a demonstration of the servo system for the increased load.

A study was also performed by General Electric Company for Naval Air Engineering Center under Contract NAEC N00156-71-C-0739 to investigate the feasibility of a weapons loader concept utilizing two articulated arms mounted on a self-propelled vehicle (Figure 13).

It is anticipated that these and other studies will lead to the development of operational hardware which will improve the efficiency of cargo and ordnance handling by utilizing and expanding on technology developed on the Hardiman program.

NOT REPRODUCIBLE

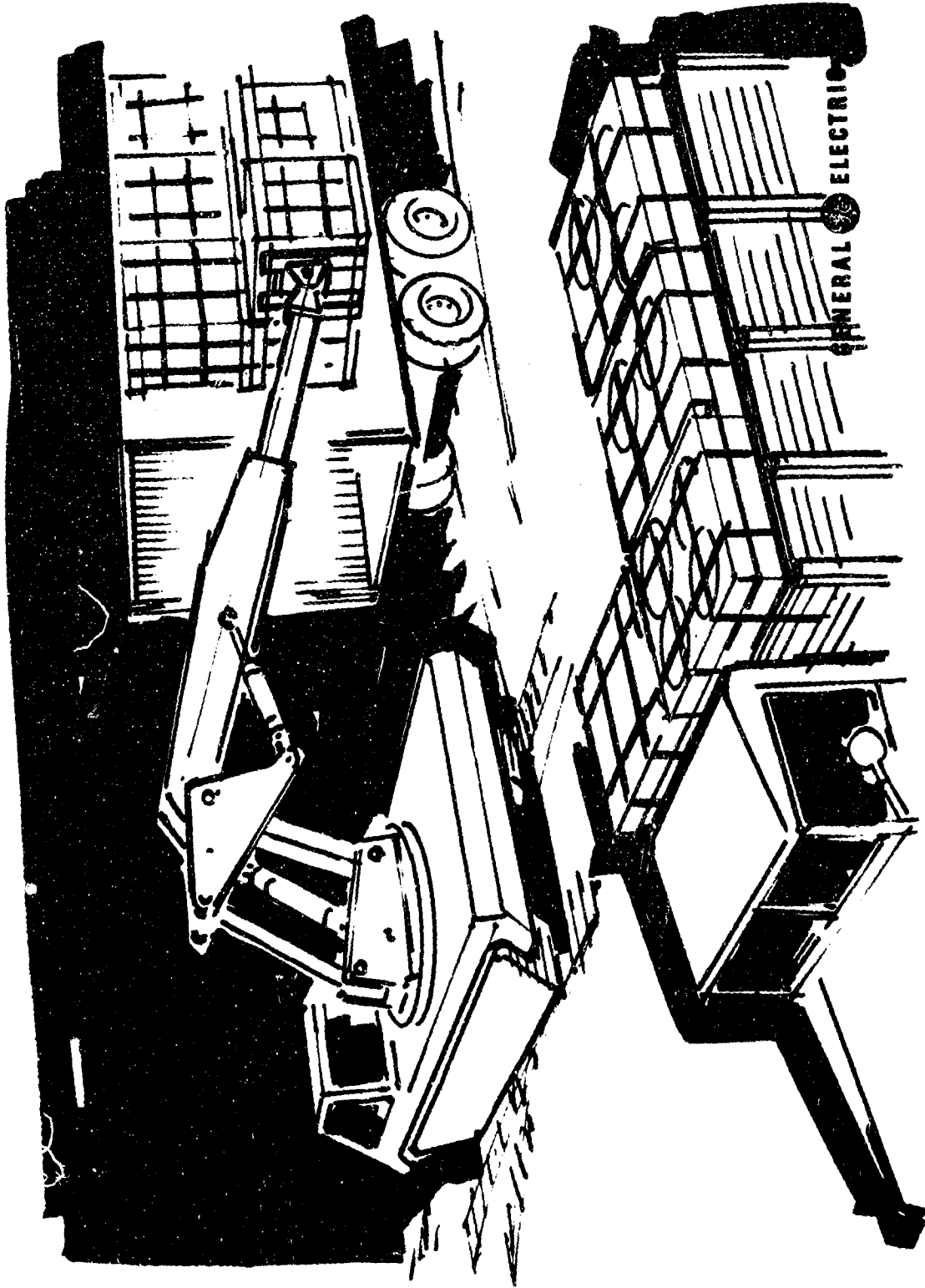
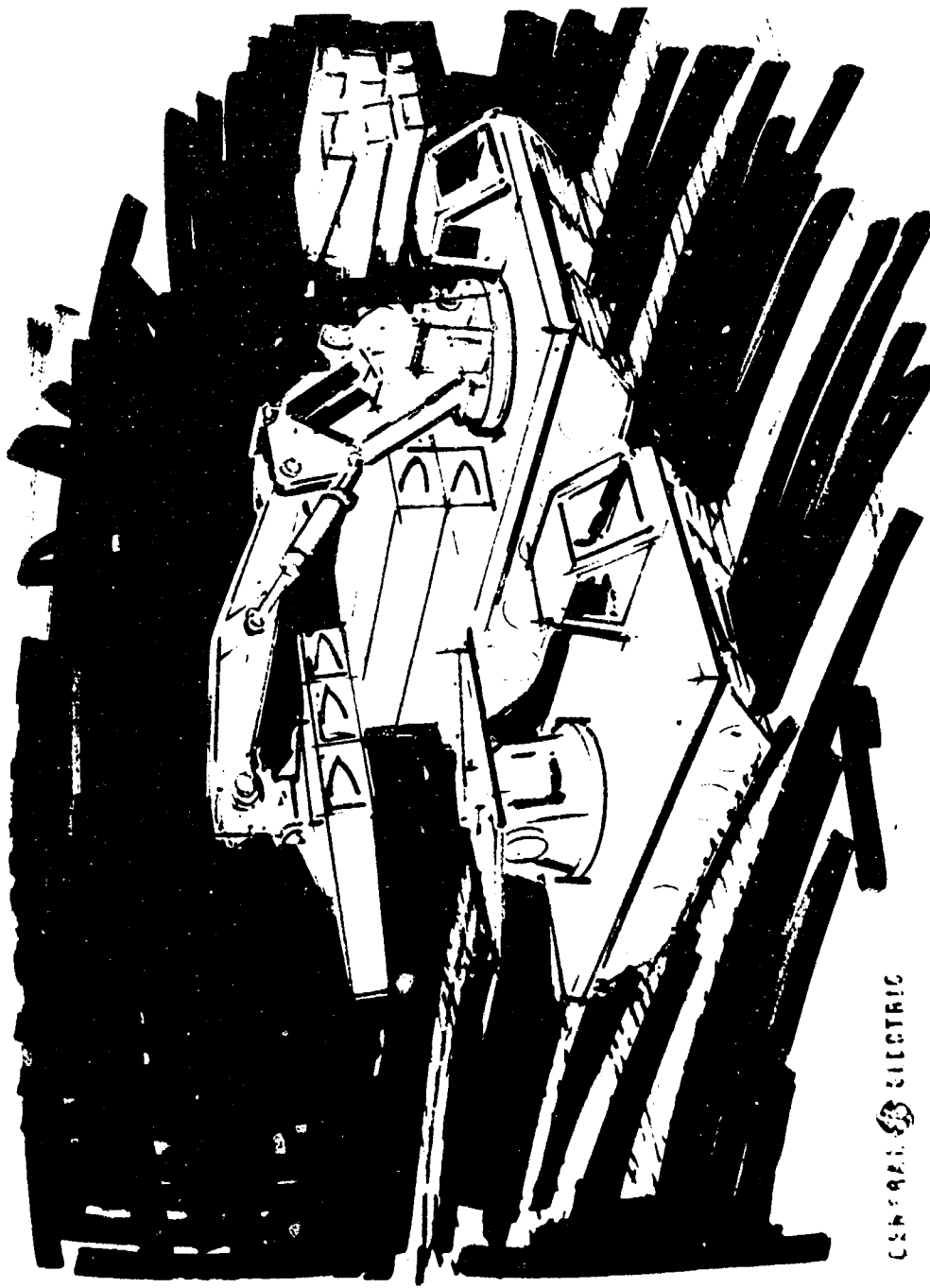

Figure 11. Boom Unloading Container  
Rapidly Unstuffing 8' x 8' x 20' Containers in Forward Areas, Using a Heavy Duty CAMS Cargo  
Boom Promises to Provide Significant Cost Savings in Labor and Equipment in Addition to  
Increasing the Unloading Rate Beyond Present Capabilities

NOT REPRODUCIBLE



CENTRAL ELECTRIC

Figure 12. Servo-controlled Cargo Boom Adapted for Rapid Loading of Missile Clips Weighing 7500 Pounds

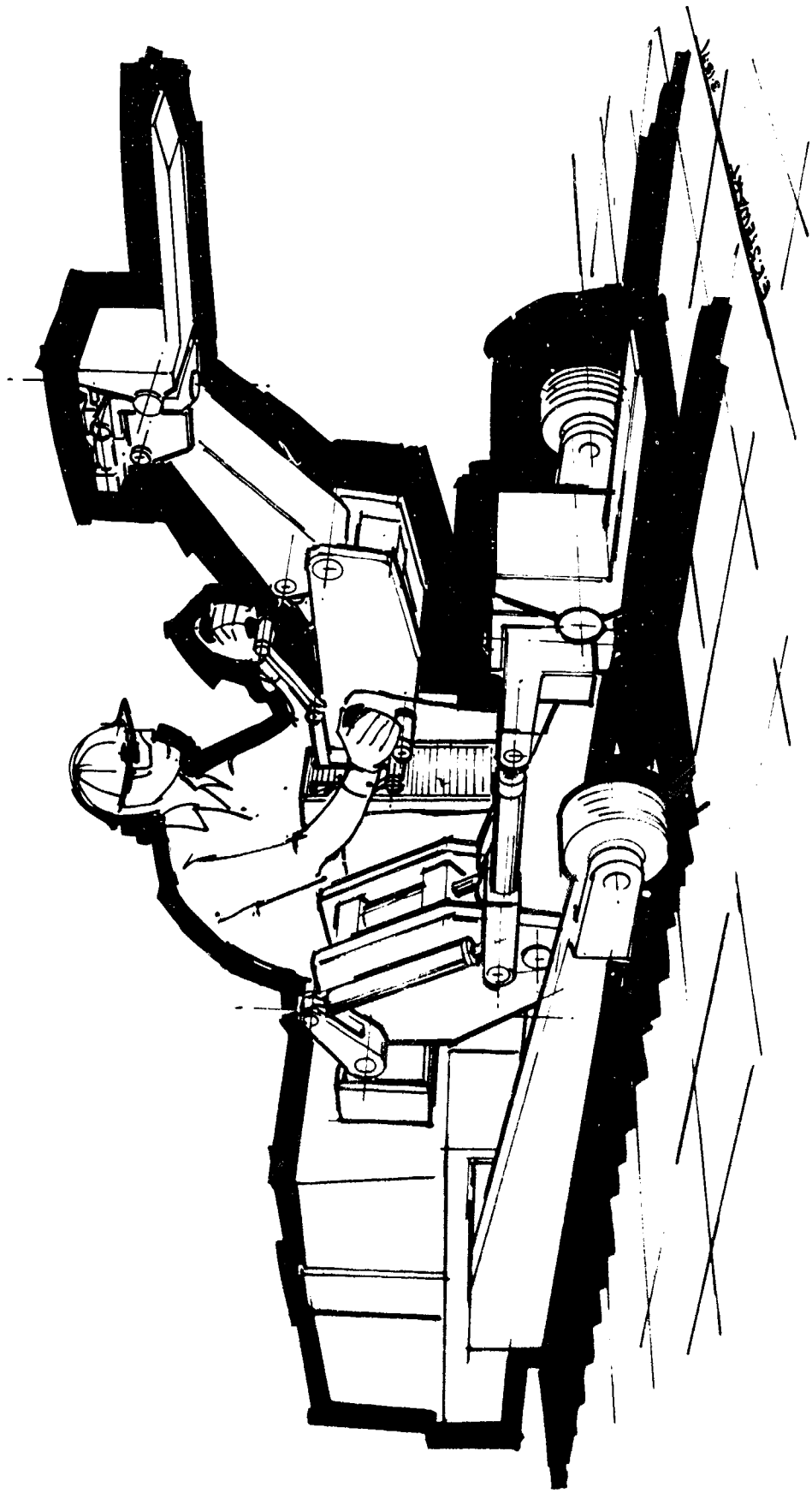

Figure 13. Two-arm Loader Concept for Ordnance Loading  
A Carrier-based Aircraft

**APPENDIX**

HARDIMAN I REPORTS

Final Report on Phase I	S-67-1011	28 Oct. 1966
Appendix to Final Report on Phase I	S-67-1016	28 Oct. 1966
Appendix X to Final Report on Phase I	S-67-1098	16 June 1967
Special Status Report	S-67-1151	30 Sept. 1967
Special Interim Study	S-68-1060	19 April 1968
Special Technical Report on Joints in Series	S-68-1081	10 June 1968
Machine Augmentation of Human Strength & Endurance	S-69-1116	1 July 1969
Hardiman I Arm Test	S-70-1019	31 Dec. 1969

TABLE A-1

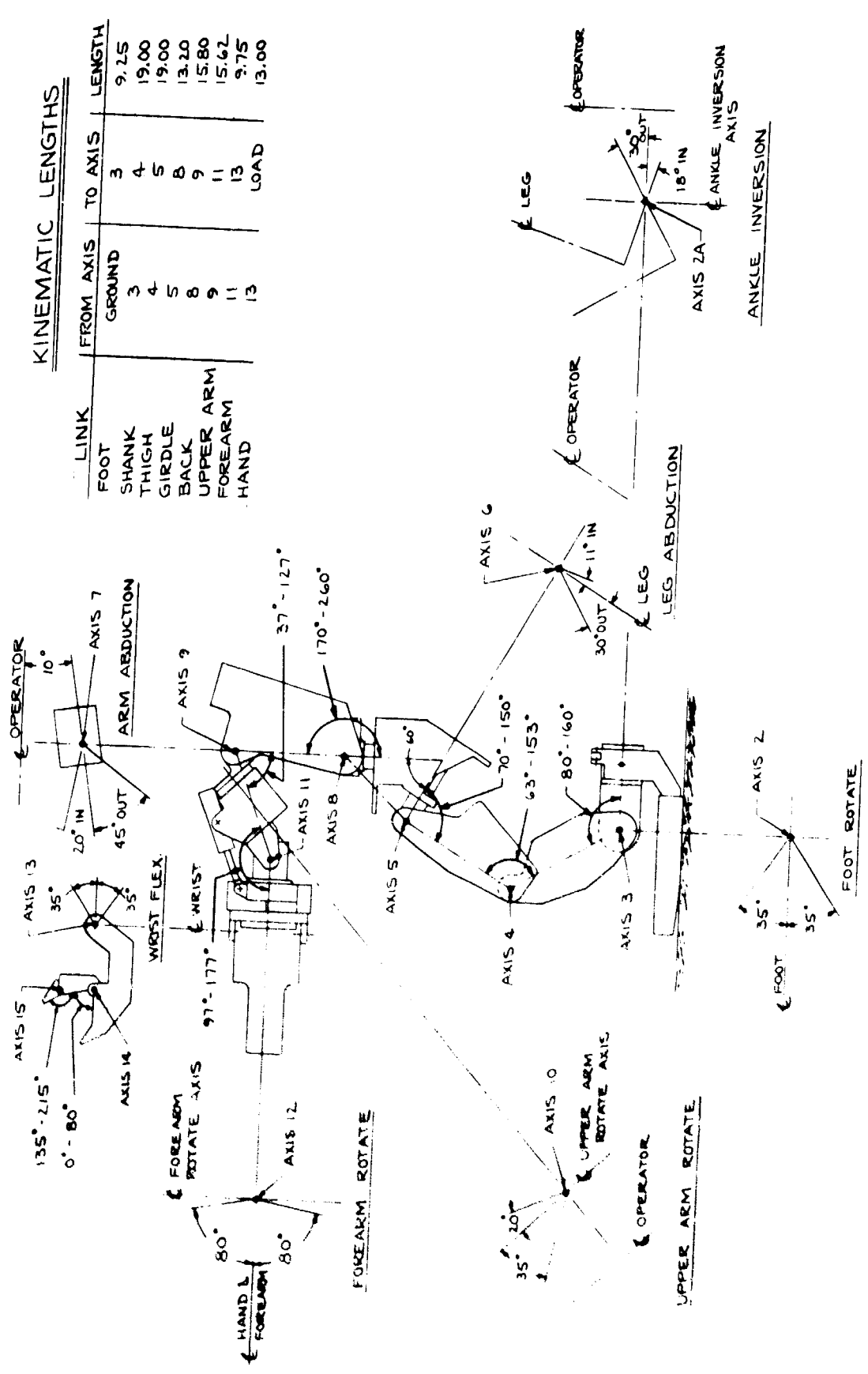

**KINEMATIC LENGTHS**

LINK	FROM AXIS	TO AXIS	LENGTH
FOOT	GROUND	3	9.25
SHANK	3	4	19.00
THIGH	4	5	19.00
GIRDLE	5	8	13.20
BACK	8	9	15.80
UPPER ARM	9	11	15.62
FOREARM	11	13	9.75
HAND	13	LOAD	13.00

Figure 14. Angular Excursions of Joints



TABLE A2  
SYSTEM SPECIFICATION

. <u>Size</u>	
Height	72"
Width (at hips)	39"
Fore & Aft	29"
. <u>Weight</u>	
	1500 lbs.
. <u>Lift Capability</u>	
	1500 lbs.
. <u>Power Requirements</u>	
Hydraulic	25 HP @ 3000 psi
Electric	± 15 V D.C. - 3 amps
. <u>Walking Speed</u>	
	2.5 ft./sec.
. <u>Reach</u>	
Vertical	72"
Horizontal	36"
. <u>Number of Joints</u>	
Hand (2 Joints)	Thumb Tip Flex Thumb Flex
Arm (7 Joints)	Wrist Flex Forearm Rotate Elbow Flex Upper Arm Rotate Shoulder Flex Back Flex Arm Abduction - Arm Adduction
Leg (4 Joints)	Hip Abduction - Arm Adduction Hip Flex Knee Flex Ankle Flex
Foot (2 Joints)	Ankle Inversion Foot Rotate
Total - 15 per side x 2 = 30 Joints	
. <u>Type of Controls</u>	
Hand	Hydromechanical Rate Control with Force Feedback.
Arm	Electrohydraulic Bilateral Servo Control. Force Feedback Ratio 25:1.
Leg and Foot	Electrohydraulic Unilateral Servo. Indirect Force Feedback.