

Arbeitsgemeinschaft der
Hauptschule Rossbach (Sieg).

beetle

Beetles, tortoises and the like have often served as models for cybernetic machines which must also have a reasonable appearance. The beetle described in this article can 'see, hear and feel' and reacts to information in the form of sounds and movements. The animal has a memory and can get tired. The beetle is the first of a series of articles on cybernetic models.

The behaviour of the beetle: action and reaction

In daylight (vertical light) the model moves slowly forward in a circle (counter-clockwise) with a diameter of approx. 80 cm. If during its journey the beetle arrives in a place where there is less light (for instance in a dark corner or below a chair), it rests in the shade for approx. half a minute to a full minute and then resumes its circular journey.

It is also possible that, instead of continuing the model decides to take a prolonged rest in the shade: it 'falls asleep'. This condition of prolonged rest can only be altered by external stimuli. The object casting the shadow is removed or the model is awakened by a loud sound (clapping). If the beetle 'sees' a horizontal light source on its journey, it makes a beeline for it. Any deviations from its course are automatically corrected.

If the model hits an obstacle on its path, it gives a brief cry of fright and immediately shrinks back. This reverse movement is, however, preceded by a short turn, so that when the beetle resumes its forward movement after 3-4 seconds, it is positioned obliquely with respect to its previous direction of travel. Because the beetle can now no longer see the light source, it again starts a left turn, which results in a second collision with the obstacle, somewhat more to the left than the first time. Thus, after a few repetitions, extensive obstacles are also dodged, after which the beetle heads for its goal (phototropism).

When the horizontal light source is reached, the model will collide with it and the above-mentioned swerving movements will follow. As a result, the model will find its way behind the light source. If this horizontal light source does not emit light backwards and if there is also a shady area at the rear of the lamp, the model goes behind the lamp to enjoy a short or prolonged period of rest.

The model can also learn. If at the moment of the collision a warning sound (clapping) is made, the model concludes that the collision (pain) and clapping

belong together. For this reason, if a warning sound is made when the model is moving forwards, it will now first give a cry of fright and then perform the same swerving movement which would otherwise be performed in the case of an actual collision.

The memory fades, however, during a rest in the shade. After such a pause the model hesitates briefly when the warning sound is made; it listens for a moment and immediately after the hand-clapping the forward movement is resumed.

In general this simple cybernetic model behaves in a typically animal-like way. It can move, see, hear, feel, it reacts efficiently to certain external interferences, acts purposefully and has also certain reflexes in addition to the senses of touch and hearing.

Things become even more interesting if two models are available, each with a light source on its back. If moreover the cry of fright of one beetle is tuned to the warning sound of the other, an exchange of experience may take place. The innumerable possibilities of searching, pursuing and swerving guarantee an interesting course of experiments.

As is indicated by dashed lines in the block diagram (figure 1) a 'hunger' sensation can be added. This part immediately interrupts a journey or a period of rest when the battery voltage drops below a

certain minimum. The model then heads for a second lamp placed near a charging unit. If on the way to the charging unit the beetle starts to use less current for some reason, it records that sufficient energy is still left to resume the normal search for the first lamp. If this effect is undesirable, a flip-flop can be used instead of gates N_{15}/N_{16} . After charging the reset function must be performed by hand.

For demonstrations it is advisable to use a potentiometer as supply control; the beetle's 'hunger' may then be artificially generated by increasing the potentiometer's resistance.

The various functions

The drive motor (DM) runs only if the vertical-light receiver (VLR) receives light from above and the warning receiver (WSR) does not receive sound, or, in darkness, if a short rest (SR 40 sec.) initiated by the VLR has elapsed and the flip-flop (LR) for a prolonged rest is not in 'prolonged' position. A warning sound makes the motor stop briefly and trips the flip-flop for prolonged rest. Furthermore the drive motor starts running if a warning unit (BW) detects a drop in battery voltage. (The latter applies only if the relevant control unit consisting of a sensor, a change-over switch COS_2 and a receiver for the light from the charging unit (CLR) has been incorporated.)

When an obstacle is touched (OS closes) CF 1/2 sec. changes over to cry of fright and RM 3 sec. to reverse movement. CF 1/2 sec. starts the cry of fright by means of an oscillator (FO). RM 3 sec. switches the drive motor to position 'reverse' by means of a relay (RRL). CF 1/2 sec. also 'enables' the memory flip-flop (MFF) for half a second, i.e. it renders the flip-flop able to receive a triggering signal. The memory flip-flop (MFF) is switched on if within this time a pulse from the warning-sound receiver (WSR) reaches MFF. Once MFF has been set, a warning sound causes CF 1/2 sec. and RM 3 sec. to be activated via a

cybernetic

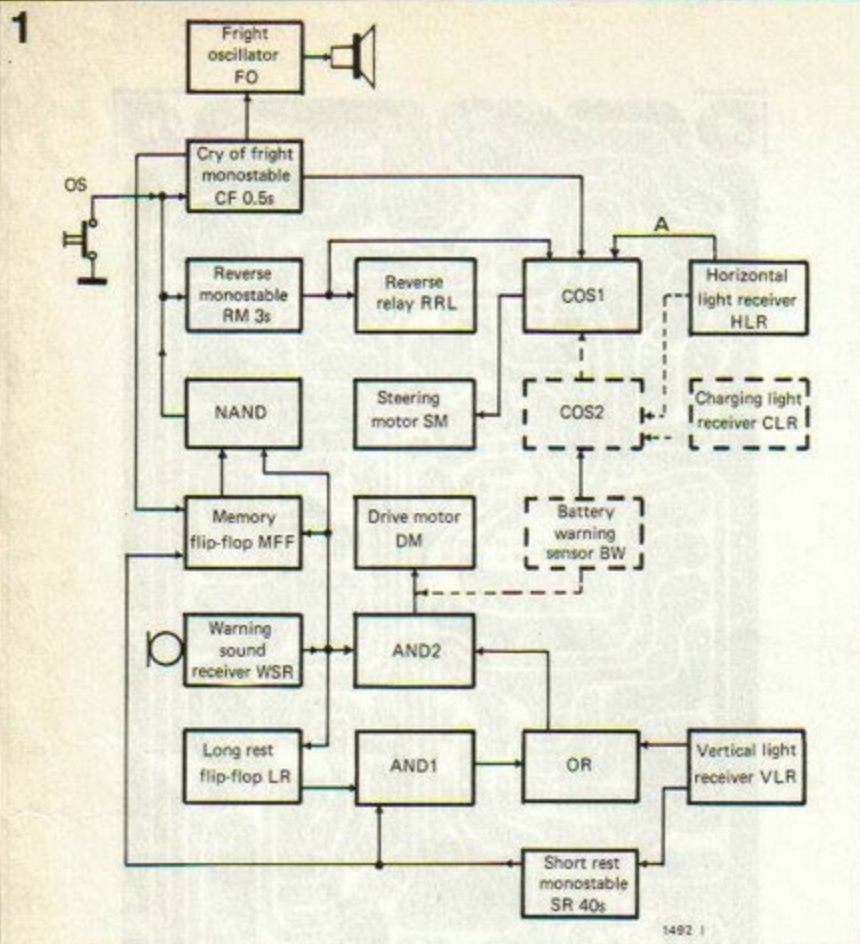
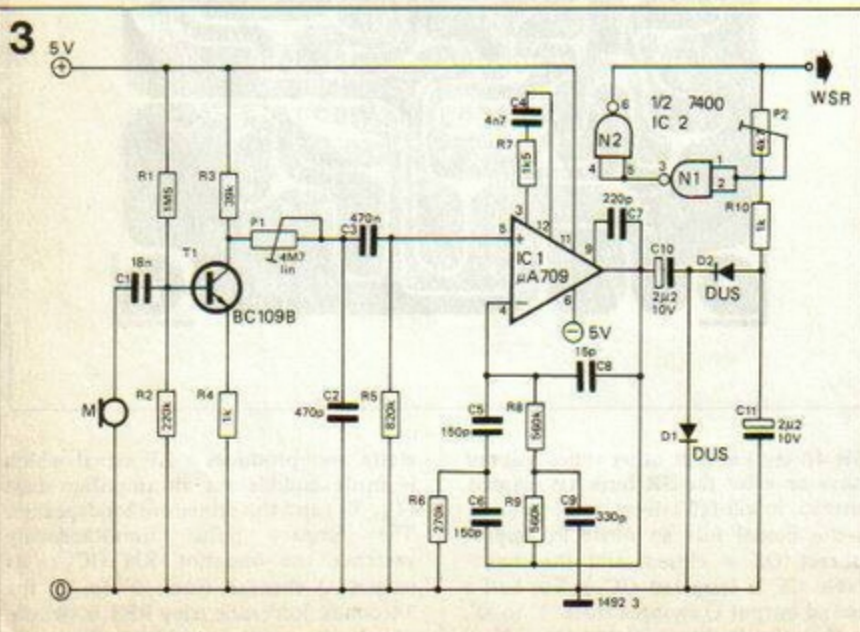
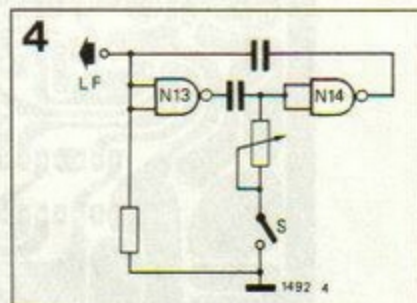
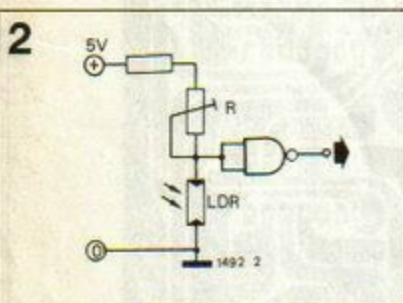

Figure 1. The block diagram shows the various 'sense organs' of the beetle; three light receivers (for vertical, horizontal and charging light), a warning-tone receiver and an impact contact for tactual stimuli. The information obtained from these organs affects the behaviour of the model via the motor, the steering motor and the reversing relay. A special sensor checks the operating voltage and ensures that the beetle makes for the 'food station' in time.

Figure 2. The circuit for the light receiver. Three of such receivers are required.

Figure 3. The warning-sound receiver.

Figure 4. Fright oscillator with two NAND's.



NAND network. This reaction is switched off by SR 40 sec., which resets MFF.

The light receiver for horizontal light (HLR) switches the steering wheel to its central position via a change-over switch (COS_1) and the steering motor (SM). The change-over switch furthermore ensures that after the collision with the obstacle the reverse movement starts with a short turn.

If the automatic 'hunger sensation' is built in, connection A runs through change-over switch COS_2 . In this way it is ensured that at a given voltage the steering motor is no longer operated by the light receiver HLR, but by the light receiver for the charging unit CLR (via COS_2 and COS_1).

Light receivers

The circuitry of the three light receivers is identical (figure 2). Each consists of a NAND gate with a voltage divider consisting of two resistors and an LDR at the input. When illuminated, the LDR has a very low resistance, so that the NAND input is logically '0' and the output is logically '1'. In the absence of light, the resistance of the LDR is high. The NAND input is at positive potential and the output is at low potential (logically '0'). The LDR for vertical light (VLR) is mounted on the model's back. The output of the relevant receiver circuit controls the period of rest (SR 40 sec.). The LDR of the receiver for horizontal light (HLR) is accommodated in a black cylinder, approx. 10 cm long, together with a converging lens. In the model this 'viewing tube' is fitted horizontally and pointing forwards. If light from the light source reaches the LDR, the output of the receiver becomes logic '1'.

Via the change-over switch(es) (COS_2 and) COS_1 the receiver HLR controls the steering motor of the model. The LDR of the receiver for the light from the charging unit must be screened from other light by means of a cylinder and, for instance, be fitted to the underside of the model so that only light from the charging unit can be received. Change-

Cybernetic

over switch COS_2 is controlled by the output of the charging light receiver CLR.

The warning receiver WSR

To prevent the beetle from reacting to any arbitrary external noise, the receiver must be selective. The 'clap sensor' of figure 3 is eminently suitable. It consists of a preamplifier (T_1), a selective amplifier with twin-T network (IC_1), a rectifier circuit (D_1, D_2) and a trigger circuit (N_1, N_2). In the digital part of the model (figure 5) the output of the trigger is followed by a one-shot (IC_{12}) set by clapping once. This one-shot can be considered as part of the receiver WSR in figure 1.

The fright oscillator FO

An astable multivibrator consisting of two NAND gates constitutes the fright oscillator (figure 4).

Switch S is the on/off switch. In the model the output of a one-shot replaces this switch. The LF output drives a low-power audio output stage.

The complete circuit

The description from the behavioural pattern shows that the model may move when sufficient light falls from above. In the absence of vertical light the model may only move if the flip-flop LR for the period of rest is in position $Q = '1'$ and if furthermore the circuit for the pause in the shade SR 40 sec. is reset ($\bar{Q} = '1'$).

These two possibilities are checked by the AND circuit consisting of N_5 and N_6 (AND_1) and the subsequent OR circuit (N_7, N_8 and N_3).

Furthermore the model may not move when the sound receiver WSR receives a signal which makes the \bar{Q} output a logic '0'. This condition is combined with the conditions previously mentioned by means of N_4 (AND_2). The output of N_4 is only a logic '0' if the conditions for moving have been fulfilled and no warning sound is received, because only in that case are the two inputs of N_4 logically '1' and the output logically '0'.

The flip-flop for a prolonged period of rest LR is tripped by output \bar{Q} of the warning sound receiver (IC_{12}) at every clap. For this reason the model will sometimes rest for the normal period

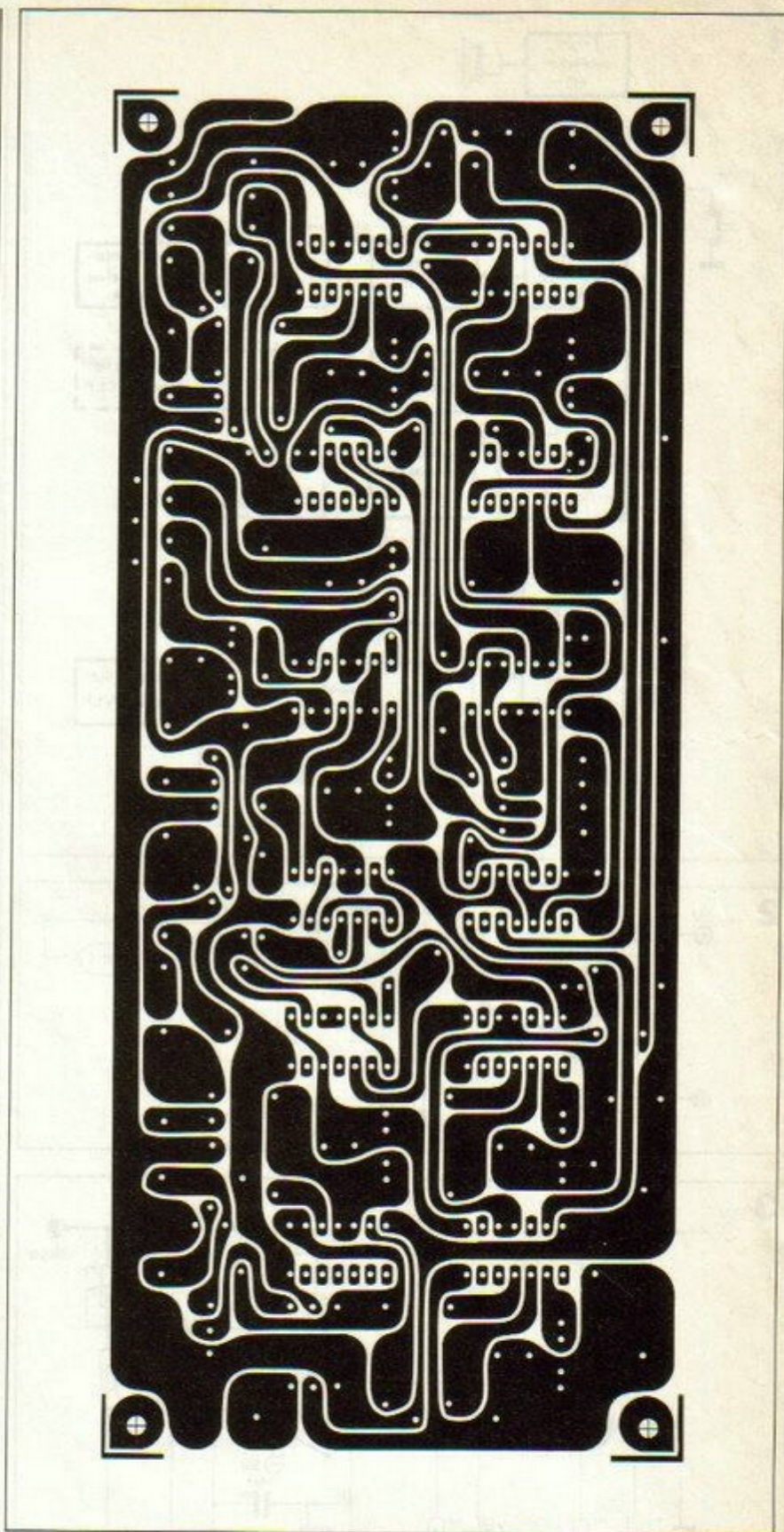

(SR 40 sec.) and at other times will not move on after the SR time has elapsed. Instead, it will fall asleep.

If the model hits an obstacle, impact contact OS is closed, and the monostable CF is triggered (IC_1). For half a second output \bar{Q} changes from '1' to '0', so that the fright oscillator (N_{13}, N_{14})

starts and produces a LF signal which is made audible via an amplifier stage (T_1, T_2) and the miniature loudspeaker. The 'impact pulse' simultaneously switches the one-shot RM (IC_2). Its output Q changes from '0' to '1' for 3 seconds. Reversing relay RRL is switched on via a power amplifier (T_5); the

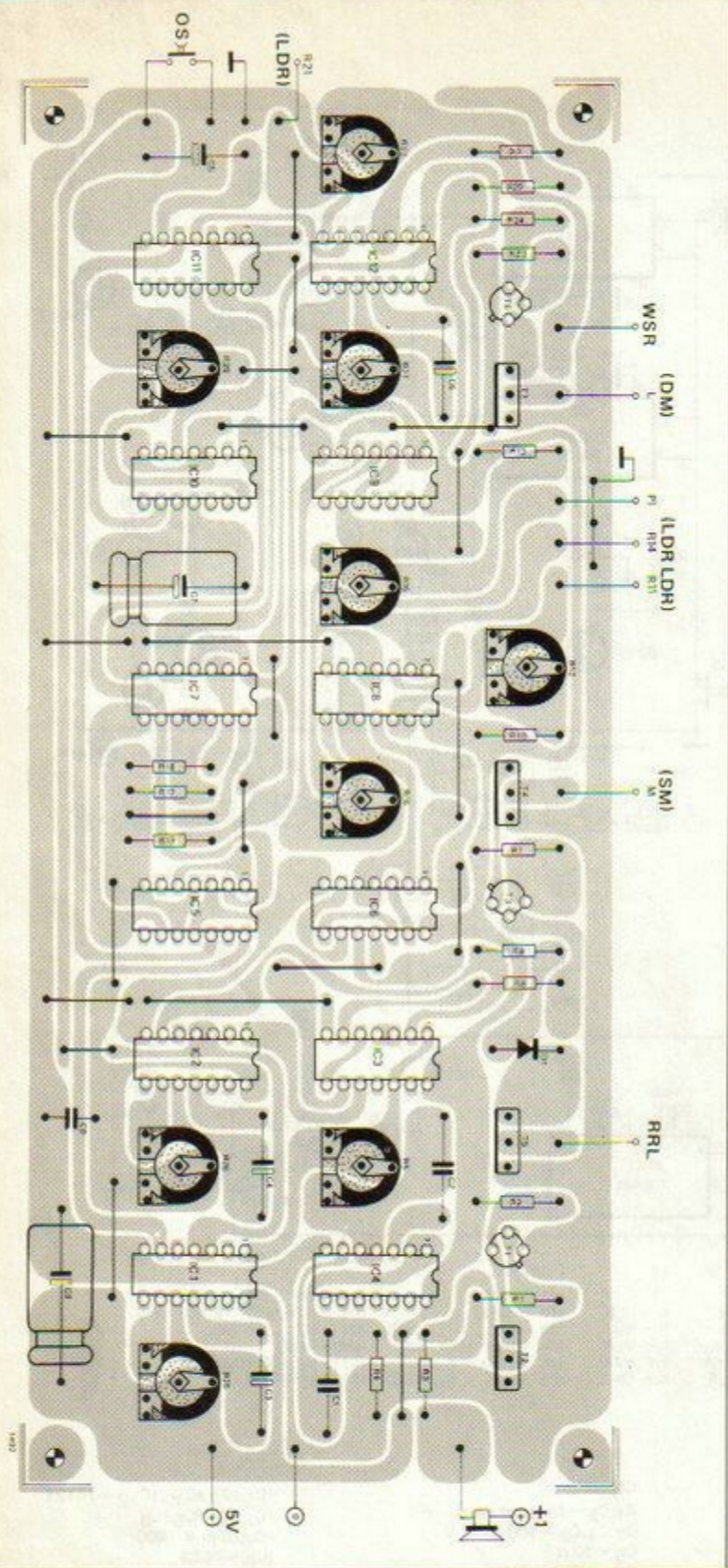

model moves backwards for approx. 3 seconds and thus moves away from the obstacle. The \bar{Q} output of CF and the Q output of RM control gate N_9 in change-over switch COS_1 . During forward movement the inputs of N_9 are at '1' and '0', so that the output is logically '1'. As the input of N_{10} controlled by

RM is at '1' in this case, the steering motor is switched on (straight ahead), via N_{11} , T_3 and T_4 , if the second input of N_{10} is also logically '1' and conversely. The signal to this second input does not affect the steering however, during the reverse movement for 3 seconds because the \bar{Q} output of RM is '0'. This means

that the reverse movement is started with a turn (0,5 sec., determined by CF via N_9), after which the movement is continued in a straight line backwards for another 2,5 sec. Then the relay lets go and the model starts moving forward again in a circle.

The memory flip-flop (MFF, IC₅) has an input J connected to the Q output of CF. Every collision causes J to become '1' for 0.5 sec. If within this time a warning sound is heard the output Q of MFF changes to '1'. Consequently a negative pulse occurs at the output of N_{12} every time a clap is heard, which causes the cry of fright and the reverse movement even without a collision occurring (reflex). When the beetle rests in the shade MFF is reset via the 'clear' input ($Q = '0'$). The memory has now been erased, so that a warning sound can only change over LR and cause the model to stop briefly (via N_4).

As the time available for the reception of information by MFF is fairly short (0.5 sec.), it is often difficult to set the flip-flop by means of clapping. This is similar to a normal learning procedure, where it may also happen that only the second or even third combination of a warning sound together with the collision results in the desired reaction.

The circuit for a rest in the shade SR also comprises a one-shot (IC₁₀) which in this case is controlled by the receiver for vertical light VLR via gate N_1 . The motor is stopped for 40 sec. via $N_5 \dots N_7$, N_3 , N_4 and N_2 , provided that meanwhile the model does not receive any light from above. The circuit for 'hunger' comprises among other things a threshold-value detector consisting of P_1 and N_{16} . P_1 can be set so that the input of N_{16} becomes logically '0' if the operating voltage has dropped to such a level that the accumulator must be recharged or the battery must be renewed. There must be sufficient energy left, however, to enable the beetle to reach the 'food station'. Because the life of the beetle is in danger when the voltage drops, protective functions, such as rest and panic stop are of secondary concern and are therefore cut out. The motor runs constantly via N_{15} and N_2 .

The output of N_{18} (in COS_2) is '1', whether there is horizontal light or not. As long as no collision occurs, only the receiver for the charging light (CLR) affects the steering motor via the input of gate N_{10} controlled by N_{20} . A collision is dealt with as usual; the effect of CLR is then cut out for 3 seconds.

The mechanical construction

A commercially-available servomotor (max. 3 V) for model planes is eminently suitable as a steering mechanism. The motor must automatically return to its central or zero position. Building-in should be done at the front of the model, on the centre-line of the bottom plate (see figure 6). The motor must be fitted with approximately 20° slant to the left, so that the model describes a left turn

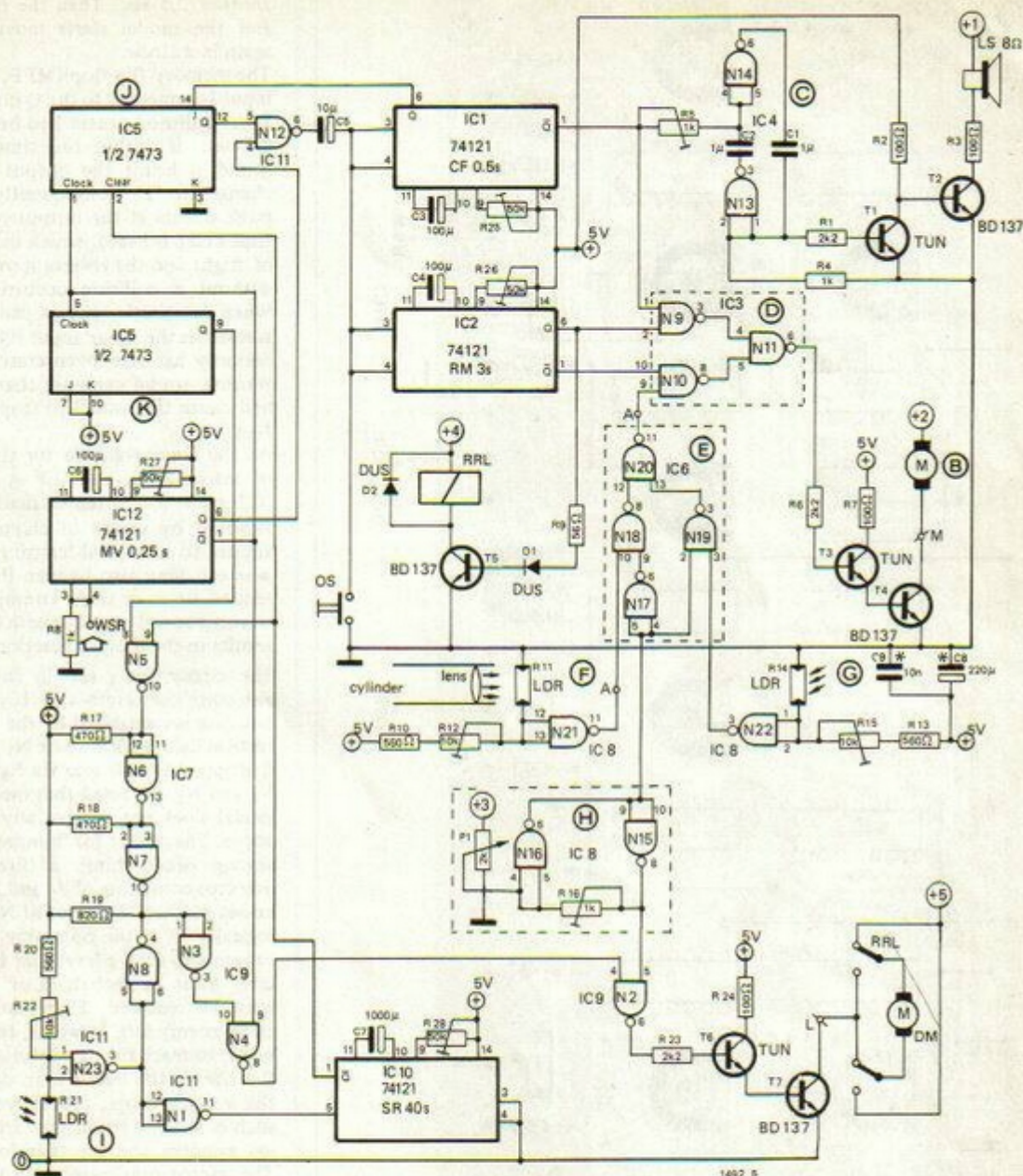

* see text

B = SM	G = CLR	IC1 = 74121	IC7 = N5 ... N8 = 7401
C = FO	H = BW	IC2 = 74121	IC8 = N21, N22, N15, N16 = 7400
D = COS1	I = VLR	IC3 = N9 ... N11 = 7400	IC9 = N2 ... N4 = 7400
E = COS2	J = MFF	IC4 = N13, N14 = 7400	IC10 = 74121
F = HLR	K = LR	IC5 = 7473	IC11 = N1, N23, N12 = 7400
		IC6 = N17 ... N20 = 7400	IC12 = 74121

Parts list for figure 5.

Resistors:

R1, R6, R23 = 2k2
 R2, R3, R7, R24 = 100 Ω
 R4, R8 = 1 k
 R5, R16 = 1 k preset
 R9 = 56 Ω
 R10, R13, R20 = 560 Ω
 R11, R14, R21 = LDR
 R12, R15, R22 = 10 k preset
 R17, R18 = 470 Ω
 R19 = 820 Ω
 R25, R26, R27, R28 = 50 k preset
 P1 = 2 k lin

Capacitors:

C1, C2 = 1 μ (not elco)
 C3, C4, C6 = 100 μ/10 V
 C5 = 10 μ
 C7 = 1000 μ/10 V
 C8 (see Text) = 220 μ/10 V
 C9 (see Text) = 10 n

Semiconductors:

D1, D2 = DUS
 T1, T3, T6 = TUN
 T2, T4, T5, T7 = BD 137

IC's:

IC1, IC2, IC10, IC12 = 74121
 IC3, IC4, IC6, IC8,
 IC9, IC11 = 7400
 IC5 = 7473
 IC7 = 7401

Sundries:

Relay: 2 x on-off
 Drive motor
 Steering motor and mechanism
 Loudspeaker LS = 8 Ω

Cybernetic

7

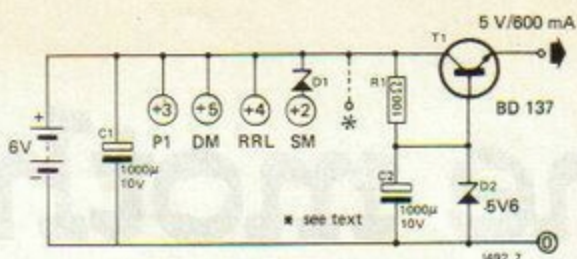

D1 = e.g. ZX3.9 (1 W), with adequate cooling if drivemotor draws more than 250mA.

6

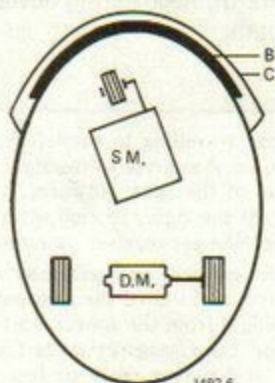

1402 6

when the rear wheels are driven.

If a positive voltage is supplied to the base of the steering transistor (T_4), this transistor conducts; the collector current passing through the steering motor pulls the steering wheel straight. If the model loses 'sight' of its target, the steering transistor is cut-off, the steering motor together with the steering wheel returns to the neutral position, which means turning in a circle.

The drive motor used is a commercially-available toy motor with reduction gearing. A low current consumption is a criterion for the choice of motor. The model must move slowly, approx. 10 cm/sec. Only the right-hand rear wheel is driven, the left-hand wheel rotating freely round its axle. The diameter of the wheels is 5-6 cm (model-plane wheels). The base plate is oval and approximately 30 cm long (figure 6). A metal strip B, approximately 1 cm high is fixed to the front of the base plate, and subsequently a bent piece of wire (C) is fitted in front of the strip. B and C together constitute impact contact OS. The metal strip and wire must be bent around the front of the model over such a distance that the impact contact also functions when the model hits an obstacle at an angle.

Current supply

Because the most common and highest voltage in the circuit is 6 V, the design was based on a 6-V battery. The drive motor, the turning relay and the l.f. amplifier for the warning sound also operate at a voltage of 6 V, so that no problems will occur.

The voltage for the steering motor is usually lower. This voltage depends on the type of motor used. If it is rated at 2.4 V, for instance, a 3.9-V series voltage-reference diode ensures that the correct voltage is available for the steering motor. A simple 5 V stabilised supply is incorporated for the rest of the circuit. Capacitors C_8 and C_9 (figure 5) are included for suppression of possible interference pulses originating from the drive motor, the steering motor and the reversing relay.

Figure 5. The complete circuit diagram of the digital section. As no particular types are specified for the drive motor, steering motor, relays and loudspeaker, the indications of voltage values near the positive connections have been omitted.

Figure 6. The position of the drive motor with the driving wheel and the free-running wheel, steering motor complete with steering wheel and the impact contact.

Figure 7. An example of a supply unit based on components that are usually commercially available, such as a 6-V drive motor and turning relay.

